

# MITSUBISHI

---

# MELSECNET/10

# Network Module

---

User's Manual  
(Hardware)

## AJ71LP21GE

Thank you for buying the Mitsubishi general-purpose programmable controller MELSEC-A Series

Prior to use, please read both this manual and detailed manual thoroughly and familiarize yourself with the product.



MODEL	AJ71LP21GE-U-E
MODEL CODE	13J813
IB(NA)-66590-E(1112)MEE	

## ● SAFETY PRECAUTIONS ●

(Always read before starting use.)

Before using this product, please read this manual and the relevant manuals introduced in this manual carefully and pay full attention to safety to handle the product correctly.

The instructions given in this manual are concerned with this product. For the safety instructions of the programmable controller system, please read the CPU module user's manual.

In this manual, the safety precautions are classified into two levels: "⚠WARNING" and "⚠CAUTION".

### **⚠WARNING**

Indicates that incorrect handling may cause hazardous conditions, resulting in death or severe injury.

### **⚠CAUTION**

Indicates that incorrect handling may cause hazardous conditions, resulting in minor or moderate injury or property damage.

Under some circumstances, failure to observe the precautions given under "⚠CAUTION" may lead to serious consequences.

Observe the precautions of both levels because they are important for personal and system safety.

Make sure that the end users read this manual and then keep the manual in a safe place for future reference.

## **[DESIGN PRECAUTIONS]**

### **⚠WARNING**

- When there are communication problems with the data link, the communication problem station will enter the following condition. Build an interlock circuit into the sequence program that will make sure the system operates safely by using the communication state information.

Not doing so could result in erroneous output or erroneous operation.

(1) For the data link data, the data prior to the communication error will be held.

### **⚠CAUTION**

- Do not bundle the control wires and communication cables with the main circuit or power wires, or install them close to each other. They should be installed at least 100 mm (3.94 inches) away from each other. Failure to do so may generate noise that may cause malfunctions.

## **[INSTALLATION PRECAUTIONS]**

### **⚠CAUTION**

- Use the programmable controller in an environment that meets the general specifications contained in CPU module user's manual. Using this programmable controller in an environment outside the range of the general specifications could result in electric shock, fire, erroneous operation, and damage to or deterioration of the product.

- Fully insert the projection on the bottom of the module into the hole in the base unit and press the module into position.

Not installing the module correctly could result in malfunction, damage, or drop of some pieces of the product.

If using the product in a vibratory environment, tighten the module with the screws.

Always tighten the module fixing screws within the specified torque range.

Loose tightening could result in drop of some pieces of the product, short-circuit, and malfunction.

Tightening the screws too much could result in drop of some pieces of the product, short-circuit, or malfunction due to the breakage of a screw or the module.

## [INSTALLATION PRECAUTIONS]

### CAUTION

- Do not directly touch the printed circuit board, the conducting parts and electronic parts of the module. It may cause damage or erroneous operation.
- Before handling the module, touch a grounded metal object to discharge the static electricity from the human body. Failure to do so may cause malfunction or failure of the module.
- Completely turn off the externally supplied power used in the system before mounting or removing the module. Not doing so could result in damage to the product.

## [WIRING PRECAUTIONS]

### WARNING

- Before wiring, be sure to shut off all phases of the external power supply used by the system. Failure to do so may cause electric shocks or damage the product.

### CAUTION

- Be sure there are no foreign substances such as sawdust or wiring debris inside the module. Such debris could cause fires, damage, or erroneous operation.
- Solder coaxial cable connectors properly. Incomplete soldering may result in malfunctioning.
- Make sure to place the communication and power cables into a duct or fasten them using a clamp. Cables not placed in the duct or not clamped may hang or shift, allowing them to be accidentally pulled, which may cause a module malfunction and cable damage.
- When removing the communication cable or power cables from the module, do not pull the cable. When removing the cable with a connector, hold the connector on the side that is connected to the module. When removing the cable connected to the terminal block, first loosen the screws on the terminal block. Pulling the cable that is still connected to the module may cause malfunction or damage to the module or cable.

## [STARTUP AND MAINTENANCE PRECAUTIONS]

### CAUTION

- Please read this manual thoroughly and confirm the safety before starting online operations (especially, program modifications, forced outputs, and operating status modifications), which are performed by connecting the GX Developer via the MELSECNET/10 network system to a running CPU module of other station. Performing incorrect online operations may damage the machinery or result in accidents.
- Never disassemble or modify the module. This may cause breakdowns, malfunctions, injuries or fire.
- When using a wireless communication device such as a mobile phone, keep a distance of 25cm (9.84inches) or more from the programmable controller in all directions. Failure to do so may cause malfunctions.
- Completely turn off the externally supplied power used in the system before mounting or removing the module. Failure to do so may damage the module or result in malfunctions.
- Be sure to shut off all phases of the external power supply used by the system before cleaning or retightening the terminal screws or module mounting screws. Failure to completely shut off all phases of the external power supply may cause module breakdowns and malfunctions. If the screws are loose, it may cause the module to short-circuit, malfunction or fall off. If the screws are tightened excessively, it may damage the screws and cause the module to short circuit, malfunction or fall off.
- Before handling the module, always touch grounded metal, etc. to discharge static electricity from the human body. Failure to do so can cause the module to fail or malfunction.

## [DISPOSAL PRECAUTIONS]

### CAUTION



- When disposing of this product, treat it as industrial waste.

## ●安全注意事项●

(使用之前请务必阅读)

在使用本产品之前,应仔细阅读本手册以及本手册中所介绍的相关手册,同时在充分注意安全的前提下正确操作。

本手册中的注意事项仅记载与本产品有关的内容。关于可编程控制器系统方面的安全注意事项,请参阅所使用的CPU模块的用户手册。

在“安全注意事项”中,安全注意事项被分为“警告”和“注意”两个等级。



**警告**

表示错误操作可能造成危险后果,导致死亡或重伤事故。



**注意**

表示错误操作可能造成危险后果,导致中度伤害、轻伤或财产损失。

此外,根据情况不同,即使标注为“注意”的事项也有可能引发严重后果。这两个等级的注意事项记载的均为重要内容,请务必遵守。

请妥善保管本手册以备需要时取阅,并将本手册交给最终用户。

### 【设计注意事项】



**警告**

- 数据链接出现通信异常时,通信异常站会变为以下状态。  
应使用通信状态信息,在顺控程序上配置互锁电路,以保证系统能安全运行。否则可能由于误输出、误动作而导致事故发生。  
(1) 保持通信异常前的数据。



**注意**

- 请勿将控制线及通信电缆与主电路及动力线等捆扎在一起或相互靠得太近。应相距大约100mm以上距离。因为噪声有可能导致误动作。

### 【安装注意事项】



**注意**

- 应在所使用的CPU模块的用户手册记载的一般规格环境下使用可编程控制器。如果在一般规格范围以外的环境中使用可编程控制器,可能导致触电、火灾、误动作、产品损坏或性能劣化。
- 应将模块下部的模块固定用凸起部切实插入基板的固定孔中,以模块固定孔为支点进行安装。如果模块未正确安装,有可能造成误动作、故障或掉落。在振动较多的环境下使用时,应使用螺栓固定模块。应在规定的扭矩范围内拧紧螺栓。如果螺栓拧得过松,有可能导致掉落、短路或误动作。如果螺栓拧得过紧,有可能造成螺栓及模块破损从而导致掉落、短路或误动作。
- 请勿直接触碰模块的基板、导电部分及电子部件。  
否则可能导致模块误动作、故障。
- 在触碰模块之前,必须先触碰已接地的金属等,释放掉人体等所携带的静电。如果不释放掉静电,有可能导致模块故障或误动作。
- 在拆装模块时,必须将系统使用的外部供应电源全部断开后再进行操作。如果未全部断开,有可能导致产品损坏。

### 【配线注意事项】



**警告**

- 在配线作业等时,必须将系统使用的外部供应电源全部断开后再进行操作。如果未全部断开,有可能导致触电或产品损坏。



**注意**

- 应注意防止切屑及配线头等异物掉入模块内。否则有可能导致火灾、故障或误动作。
- 同轴电缆用接口应正确焊接。如果焊接不牢固,有可能导致误动作。

## 【配线注意事项】

### 注意

- 与模块相连接的通信电缆必须收入套管中，或者用夹具进行固定处理。  
如果未将电缆收入套管或未用夹具进行固定处理，可能由于电缆的晃动及移动、不经意的拉拽等造成模块及电缆破损、电缆接触不良而导致误动作。
- 在拆卸与模块相连接的通信电缆时，请勿用手拉扯电缆部分。  
带接口的电缆应握住与模块相连接部分的接口进行拆卸。  
如果在与模块相连接的状态下拉扯电缆，可能导致模块及电缆破损、电缆接触不良而导致误动作。

## 【启动 / 维护注意事项】

### 警告

- 在通电状态下请勿触摸接口。否则可能导致误动作。

### 注意

- 通过外围设备对其他站点在运行中的CPU模块进行在线操作（特别是程序更改、强制输出、运行状态的更改）前，应仔细阅读手册，在充分确认安全的基础上进行操作。否则操作错误有可能导致机械破损或事故发生。
- 请勿拆解或改造各模块。否则可能导致故障、误动作、人身伤害或火灾。
- 便携电话或PHS等无线通信设备应在距离可编程控制器本体（各个方向）25cm以上的地方使用。否则可能导致误动作。
- 在拆装模块时，必须将系统使用的外部供应电源全部断开后再进行操作。如果未全部断开，有可能导致模块故障或误动作。
- 在重新紧固端子螺栓、模块安装螺栓及清洁模块时，必须将系统使用的外部供应电源从外部全部断开后再进行操作。如果未全部断开，有可能导致模块故障或误动作。如果螺栓拧得过松，有可能导致掉落、短路或误动作。如果螺栓拧得过紧，有可能造成螺栓及模块破损从而导致掉落、短路或误动作。
- 在触碰模块之前，必须先触碰已接地的金属等，释放掉人体等所携带的静电。如果不释放掉静电，有可能导致模块故障或误动作。

## 【报废处理注意事项】

### 注意

- 本产品报废时，应当作工业废物处理。

## ● CONDITIONS OF USE FOR THE PRODUCT ●

- (1) Mitsubishi programmable controller ("the PRODUCT") shall be used in conditions;
  - i) where any problem, fault or failure occurring in the PRODUCT, if any, shall not lead to any major or serious accident; and
  - ii) where the backup and fail-safe function are systematically or automatically provided outside of the PRODUCT for the case of any problem, fault or failure occurring in the PRODUCT.
- (2) The PRODUCT has been designed and manufactured for the purpose of being used in general industries.  
MITSUBISHI SHALL HAVE NO RESPONSIBILITY OR LIABILITY (INCLUDING, BUT NOT LIMITED TO ANY AND ALL RESPONSIBILITY OR LIABILITY BASED ON CONTRACT, WARRANTY, TORT, PRODUCT LIABILITY) FOR ANY INJURY OR DEATH TO PERSONS OR LOSS OR DAMAGE TO PROPERTY CAUSED BY the PRODUCT THAT ARE OPERATED OR USED IN APPLICATION NOT INTENDED OR EXCLUDED BY INSTRUCTIONS, PRECAUTIONS, OR WARNING CONTAINED IN MITSUBISHI'S USER, INSTRUCTION AND/OR SAFETY MANUALS, TECHNICAL BULLETINS AND GUIDELINES FOR the PRODUCT.

("Prohibited Application")

Prohibited Applications include, but not limited to, the use of the PRODUCT in;

- Nuclear Power Plants and any other power plants operated by Power companies, and/or any other cases in which the public could be affected if any problem or fault occurs in the PRODUCT.
- Railway companies or Public service purposes, and/or any other cases in which establishment of a special quality assurance system is required by the Purchaser or End User.
- Aircraft or Aerospace, Medical applications, Train equipment, transport equipment such as Elevator and Escalator, Incineration and Fuel devices, Vehicles, Manned transportation, Equipment for Recreation and Amusement, and Safety devices, handling of Nuclear or Hazardous Materials or Chemicals, Mining and Drilling, and/or other applications where there is a significant risk of injury to the public or property.

Notwithstanding the above, restrictions Mitsubishi may in its sole discretion, authorize use of the PRODUCT in one or more of the Prohibited Applications, provided that the usage of the PRODUCT is limited only for the specific applications agreed to by Mitsubishi and provided further that no special quality assurance or fail-safe, redundant or other safety features which exceed the general specifications of the PRODUCTS are required. For details, please contact the Mitsubishi representative in your region.

### **About the Manuals**

The following product manuals are available. Please use this table as a reference to request the appropriate manual as necessary.

#### **Detailed Manual**

Manual name	Manual No. (Model code)
Type MELSECNET/10 Network System (PLC to PLC network) Reference Manual	IB-66440 (13JE33)
Type MELSECNET/10 Network System (Remote I/O network) Reference Manual	SH-3509 (13JE72)

Before use of this module, be sure to read the Type MELSECNET/10 Network System (PLC to PLC network) Reference Manual or the Type MELSECNET/10 Network System (Remote I/O network) Reference Manual.

### **COMPLIANCE WITH EMC AND LOW VOLTAGE DIRECTIVES**

#### (1) Method of ensuring compliance

To ensure that Mitsubishi programmable controllers maintain EMC and Low Voltage Directives when incorporated into other machinery or equipment, certain measures may be necessary. Please refer to one of the following manuals.

- User's manual for the CPU module used
- User's manual (hardware) for the CPU module or base unit used

The CE mark on the side of the programmable controller indicates compliance with EMC and Low Voltage Directives.

#### (2) Additional measures

To ensure that this product maintains EMC and Low Voltage Directives, please refer to one of the manuals listed under (1).

# 1. Overview

This manual explains the specifications and names of each part, etc., of the AJ71LP21GE model MELSECNET/10 network module (abbreviated as Network Modules) which are used with MELSECNET/10 network system of the MELSEC-A series.

(1) The use, cable used and installation position of the Network Modules are indicated on the following chart.

	Application	Cable used		Position
		Optical fiber cable	Coaxial cable	
AJ71LP21GE	The control station, normal station and remote master station of MELSECNET/10	○ (GI-62.5/125 cables)	-	Main base, Extension base I/O slot

(2) After unpacking the Network Modules, confirm that any of the following products is enclosed.

Model	Description	Quantity
AJ71LP21GE	Model AJ71LP21GE MELSECNET/10 network module (optical loop type)	1

(3) The remote I/O network is supported from the software version A or later.

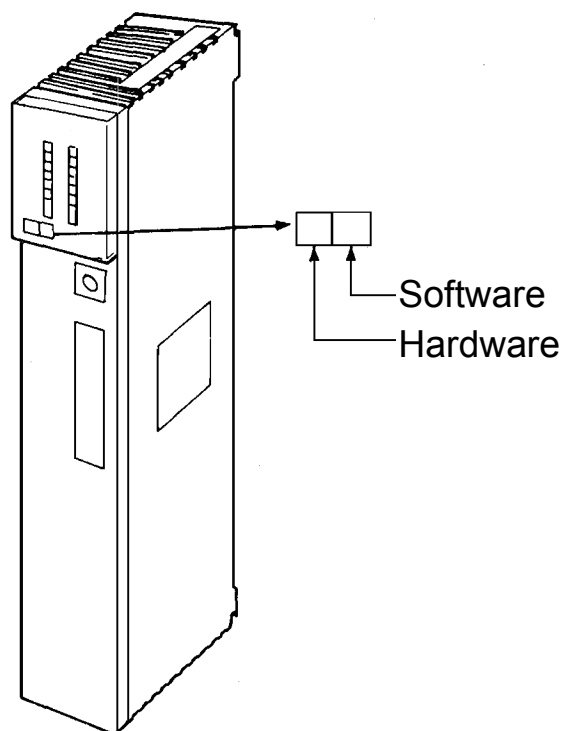

In addition, make sure to use the following software version for the CPU module applicable to the remote I/O network.

Model	Software version
A2UCPU(S1) A3UCPU A4UCPU	N or later
A2ASHCPU(S1)	D or later
A2USHCPU-S1	A or later

## 2. Performance Specifications

### 2.1 Performance specifications for the network module

The performance specifications for Network Modules are indicated as follows.

Item		Specifications
Maximum link points per network	X/Y	8192 points
	B	8192 points
	W	8192 points
Maximum link points per station	PLC to PLC network	$\left\{ \frac{Y+B}{8} + (2 \times W) \right\} \leq 2000$ bytes
	Remote I/O network	<ul style="list-style-type: none"> <li>Remote master station → remote I/O station  <math>\left\{ \frac{Y+B}{8} + (2 \times W) \right\} \leq 1600</math> bytes</li> <li>Remote I/O station → remote master station  <math>\left\{ \frac{X+B}{8} + (2 \times W) \right\} \leq 1600</math> bytes</li> </ul>
Communication speed		10Mbps (equivalent to 20Mbps for multiple transmission)
Communication method		Token ring
Synchronization method		Frame synchronization
Encoding method		NRZI encoding (Non Return to Zero Inverted)
Transmission route format		Duplex optical loop
Transmission format		Conform to HDLC (frame format)
Maximum number of networks		255 (The sum total of PLC to PLC network and remote I/O network)
Maximum number of groups		9 (Only for PLC to PLC network)
Number of stations for connection per network	PLC to PLC network	64 stations (Control station: 1 Normal stations: 63)
	Remote I/O network	65 stations (Remote master station: 1 Remote I/O stations: 64)
Overall distance (Station-to-station distance)		30km (2km)
Error control method		Retry by CRC ( $X^{16}+X^{12}+X^5+1$ ) and overtime
RAS function		<ul style="list-style-type: none"> <li>Loop back function due to abnormality detection and cable disconnection</li> <li>Diagnostic function for local link circuit check</li> <li>Prevention of system down due to shifting to control station (Only for PLC to PLC networks)</li> <li>Abnormality detection by link special relay, resistor</li> <li>Network monitor, each type of diagnostic function</li> </ul>
Transient transmission		<ul style="list-style-type: none"> <li>N:N communication (Monitor, program upload/download, etc.)</li> <li>ZNRD/ZNWR instructions (N:N) : AnUCPU dedicated instructions</li> </ul>
Connection cable		GI-62.5/125 optical fiber cable (Arranged by user *1)
Applicable connector		1-core optical connector plug (Arranged by user *1)
5VDC current consumption		0.65A
Weight		0.31kg *2
No. of occupied I/O points		32 points (I/O assignment: 32 points as special)

\*1: Specialised training and specific tools are required to connect the connector to the optical fiber cable; the connector itself is a custom product. Please contact your nearest Mitsubishi Electric System Service Corporation when purchasing these items.

\*2: The weight for the hardware version F or earlier is 0.45kg.

For general specifications of the network module, refer to the user's manual for the programmable controller CPU that is to be used.



## 2.2 GI-62.5/125 optical fiber cable specifications

### (1) Applicable cable specifications

- The specifications for the GI-62.5/125 cable are given below.
- If you prepare a GI-62.5/125 cable yourself, it must comply with the specifications indicated below.

Item	Specification
Fiber type	GI (graded index) type multimode quartz glass
Core diameter	62.5 $\mu$ m
Clad diameter	125 $\mu$ m
Transmission loss	3dB/km or less
Wave length	0.85 $\mu$ m
Transmission band	300 MHz km or more

### (2) Cable loss

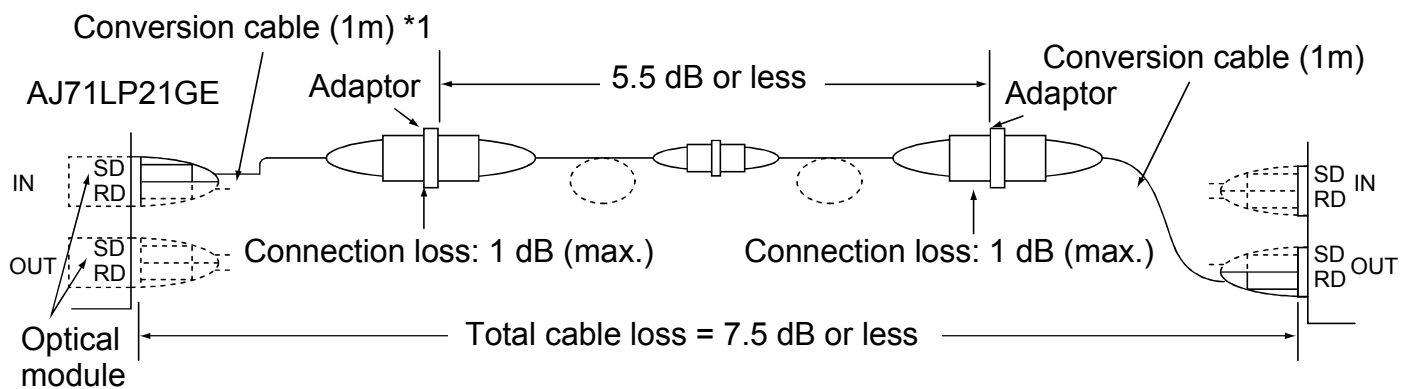

#### \*1: Conversion cable

Conversion Type	Cable
CA type ↔ FC type	AGE-1P-CA/FC1.5M-A
CA type ↔ ST type	AGE-1P-CA/ST1.5M-A
CA type ↔ SMA type	AGE-1P-CA/SMA1.5M-A

Purchased from: Mitsubishi Electric Europe GmbH

## 3. Handling

### 3.1 Cable length restrictions between stations

- (1) The main modules case is made of plastic, so do not drop it or subject it to strong impacts.
- (2) Do not dismount the printed wiring board from the case. It may damage the module.
- (3) When wiring, be careful never to let foreign matter from the above module such as wiring scraps get inside the module. If something goes in, get rid of it.
- (4) The module installation screw should be kept within the following range.

Screw Locations	Tightening Torque Range
Module installation screws (M4 screws)	78 to 118N•cm

## 4. The Name and Setting of Each Part

Indicates the name and setting of each part of Network Modules.

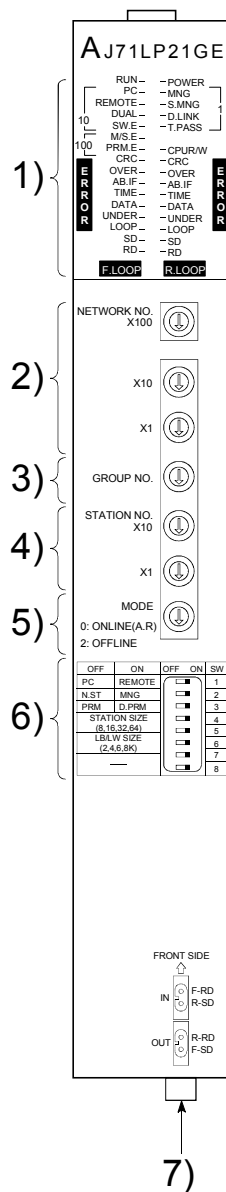

No.	Name	Contents				
1)	<div style="border: 1px solid black; padding: 5px;"> <p style="text-align: center; font-weight: bold; font-size: 1.2em;">AJ71LP21GE</p> <table style="width: 100%; border-collapse: collapse;"> <tr> <td style="width: 50%; vertical-align: top;"> <p>RUN- -POWER PC- -MNG REMOTE- -S.MNG DUAL- -D.LINK SW.E- -T.PASS M/S.E- PRM.E- -CPU R/W CRC- -CRC OVER- -OVER AB.IF- -AB.IF TIME- -TIME DATA- -DATA UNDER- -UNDER LOOP- -LOOP SD- -SD RD- -RD</p> <p style="text-align: center;">F.LOOP    R.LOOP</p> </td> <td style="width: 50%; vertical-align: top; border-left: 1px solid black; border-right: 1px solid black;"> <p style="text-align: center; font-weight: bold; font-size: 1.2em;">ERROR</p> </td> </tr> </table> </div>	<p>RUN- -POWER PC- -MNG REMOTE- -S.MNG DUAL- -D.LINK SW.E- -T.PASS M/S.E- PRM.E- -CPU R/W CRC- -CRC OVER- -OVER AB.IF- -AB.IF TIME- -TIME DATA- -DATA UNDER- -UNDER LOOP- -LOOP SD- -SD RD- -RD</p> <p style="text-align: center;">F.LOOP    R.LOOP</p>	<p style="text-align: center; font-weight: bold; font-size: 1.2em;">ERROR</p>	Name	Status	Contents
		<p>RUN- -POWER PC- -MNG REMOTE- -S.MNG DUAL- -D.LINK SW.E- -T.PASS M/S.E- PRM.E- -CPU R/W CRC- -CRC OVER- -OVER AB.IF- -AB.IF TIME- -TIME DATA- -DATA UNDER- -UNDER LOOP- -LOOP SD- -SD RD- -RD</p> <p style="text-align: center;">F.LOOP    R.LOOP</p>	<p style="text-align: center; font-weight: bold; font-size: 1.2em;">ERROR</p>			
		RUN	ON	Normal state		
		RUN	OFF	WDT error, SP.UNIT ERROR		
		PC		Set as PLC to PLC network (SW1 turned OFF)		
		REMOTE		Set as remote I/O network (SW1 turned ON)		
		DUAL		Multiplex transfer in execution (OFF: Multiplex transfer not executed)		
		SW.E.		Incorrect setting of switches 2) to 6)		
		M/S.E.		Station number or control/remote master station status is duplicated on the same network.		
		PRM.E.		<ul style="list-style-type: none"> <li>• Duplication of network refreshes parameters when multiple modules are mounted.</li> <li>• Inconsistency between the common and station specific parameters</li> <li>• Difference between parameter received from sub-control station and the one of the host (received from control station).</li> </ul>		
		POWER		Power being supplied (OFF: No power being supplied)		
		MNG		Operating as control station or remote master station (OFF: Normal station)		
		S.MNG		Operating as sub-control station		
		D.LINK		Data link being performed (OFF: Data link stopped)		
		T.PASS		Participating in token passing (Transient transmission is available.)		
		CPU R/W	ON	Communicating with CPU		
		CRC		Error detected in code check of receive data <Cause> Timing at which station sending data to target station is disconnected from network, hardware failure, cable fault, noise, etc.		
		OVER		Error occurred when receive data processing is delayed <Cause> Hardware failure, cable fault, noise, etc.		
		AB.IF		<ul style="list-style-type: none"> <li>• Consecutive 1s exceeding the specified number were received.</li> <li>• Length of received data is too short.</li> </ul> <Cause> Timing at which station sending data to target station is disconnected from network, too short monitoring time, cable fault, noise, etc.		
		TIME		Data link WDT times out. <Cause> Monitoring time too short, cable fault, noise, etc.		
		DATA		Abnormal data larger than 2 kbytes are received. <Cause> Cable fault, noise, etc.		
		UNDER		Internal send data processing is not done at fixed intervals. <Cause> Hardware failure		
		LOOP		Forward/reverse loop (F.LOOP/R.LOOP) is faulty. <Cause> Power-off of adjacent station, cable disconnection, no connection, etc.		
		SD	Dimly	Data being sent		
RD	ON	Data being received				

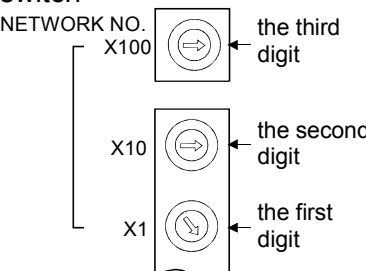
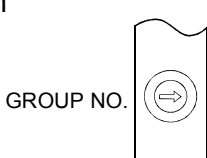
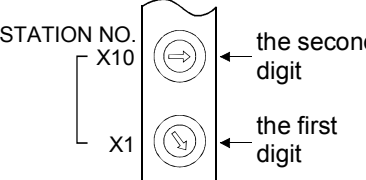
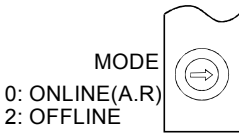
No.	Name	Contents																																															
2) *1	<b>Network number setting switch</b> 	Network number setting (factory setting at time of shipping: 1) <Setting range> 1 to 255 : Network number Other than 1 to 255 : Setting error (The SW.E. LED turns ON) Becomes off-line condition																																															
3) *1	<b>Group number setting Switch</b> 	Group number setting (factory setting at time of shipping: 0) 0 : No specified group 1 to 9 : Group number ] Enabled for PLC to PLC network																																															
4) *1	<b>Station number setting switch</b> 	<table border="1"> <thead> <tr> <th colspan="2">Station number setting (factory setting at time of shipping: 1)</th> </tr> <tr> <th>Type</th> <th>Setting</th> </tr> </thead> <tbody> <tr> <td rowspan="2">PLC to PLC network</td> <td>1 to 64 : Station number</td> </tr> <tr> <td>Other than 1 to 64 : Setting error (The SW.E. LED turns ON)</td> </tr> <tr> <td rowspan="2">Remote I/O network</td> <td>0 : Remote master station</td> </tr> <tr> <td>Other than 0 : Setting error (The SW.E. LED turns ON)</td> </tr> </tbody> </table>	Station number setting (factory setting at time of shipping: 1)		Type	Setting	PLC to PLC network	1 to 64 : Station number	Other than 1 to 64 : Setting error (The SW.E. LED turns ON)	Remote I/O network	0 : Remote master station	Other than 0 : Setting error (The SW.E. LED turns ON)																																					
Station number setting (factory setting at time of shipping: 1)																																																	
Type	Setting																																																
PLC to PLC network	1 to 64 : Station number																																																
	Other than 1 to 64 : Setting error (The SW.E. LED turns ON)																																																
Remote I/O network	0 : Remote master station																																																
	Other than 0 : Setting error (The SW.E. LED turns ON)																																																
5) *1	<b>Mode setting switch</b> 	<table border="1"> <thead> <tr> <th colspan="3">Mode setting (factory setting at time of shipping: 0)</th> </tr> <tr> <th>Mode</th> <th>Name</th> <th>Contents</th> </tr> </thead> <tbody> <tr> <td>0</td> <td>Online (automatic online return effective)</td> <td>Data link with automatic online return effective</td> </tr> <tr> <td>1</td> <td colspan="2">Not used (Setting to this turns on the SW.E. LED.)</td> </tr> <tr> <td>2</td> <td>Offline</td> <td>Disconnects the host station.</td> </tr> <tr> <td>3</td> <td>Forward loop test</td> <td>Checks the forward loop of the whole network system.</td> </tr> <tr> <td>4</td> <td>Reverse loop test</td> <td>Checks the reverse loop of the whole network system.</td> </tr> <tr> <td>5</td> <td>Station-to-station test (master station)</td> <td rowspan="2">The mode for a line check between two stations, in which the station with the smaller number is regarded as the master station and the other is considered the slave station.</td> </tr> <tr> <td>6</td> <td>Station-to-station test (slave station)</td> </tr> <tr> <td>7</td> <td>Self-loopback test</td> <td>Check the hardware of a module in isolation, including the communication circuit and cables of the transmission system.</td> </tr> <tr> <td>8</td> <td>Internal self-loopback test</td> <td>Check the hardware of a module in isolation, including the communication circuit of the transmission system.</td> </tr> <tr> <td>9</td> <td>Hardware test</td> <td>Check the hardware inside the network module.</td> </tr> <tr> <td>A to C</td> <td>Not used</td> <td>(Do not set the mode.)</td> </tr> <tr> <td>D</td> <td>Test mode 8</td> <td>Network No. check (LED display)</td> </tr> <tr> <td>E</td> <td>Test mode 9</td> <td>Group No. check (LED display)</td> </tr> <tr> <td>F</td> <td>Test mode 10</td> <td>Station No. check (LED display)</td> </tr> </tbody> </table>	Mode setting (factory setting at time of shipping: 0)			Mode	Name	Contents	0	Online (automatic online return effective)	Data link with automatic online return effective	1	Not used (Setting to this turns on the SW.E. LED.)		2	Offline	Disconnects the host station.	3	Forward loop test	Checks the forward loop of the whole network system.	4	Reverse loop test	Checks the reverse loop of the whole network system.	5	Station-to-station test (master station)	The mode for a line check between two stations, in which the station with the smaller number is regarded as the master station and the other is considered the slave station.	6	Station-to-station test (slave station)	7	Self-loopback test	Check the hardware of a module in isolation, including the communication circuit and cables of the transmission system.	8	Internal self-loopback test	Check the hardware of a module in isolation, including the communication circuit of the transmission system.	9	Hardware test	Check the hardware inside the network module.	A to C	Not used	(Do not set the mode.)	D	Test mode 8	Network No. check (LED display)	E	Test mode 9	Group No. check (LED display)	F	Test mode 10	Station No. check (LED display)
Mode setting (factory setting at time of shipping: 0)																																																	
Mode	Name	Contents																																															
0	Online (automatic online return effective)	Data link with automatic online return effective																																															
1	Not used (Setting to this turns on the SW.E. LED.)																																																
2	Offline	Disconnects the host station.																																															
3	Forward loop test	Checks the forward loop of the whole network system.																																															
4	Reverse loop test	Checks the reverse loop of the whole network system.																																															
5	Station-to-station test (master station)	The mode for a line check between two stations, in which the station with the smaller number is regarded as the master station and the other is considered the slave station.																																															
6	Station-to-station test (slave station)																																																
7	Self-loopback test	Check the hardware of a module in isolation, including the communication circuit and cables of the transmission system.																																															
8	Internal self-loopback test	Check the hardware of a module in isolation, including the communication circuit of the transmission system.																																															
9	Hardware test	Check the hardware inside the network module.																																															
A to C	Not used	(Do not set the mode.)																																															
D	Test mode 8	Network No. check (LED display)																																															
E	Test mode 9	Group No. check (LED display)																																															
F	Test mode 10	Station No. check (LED display)																																															

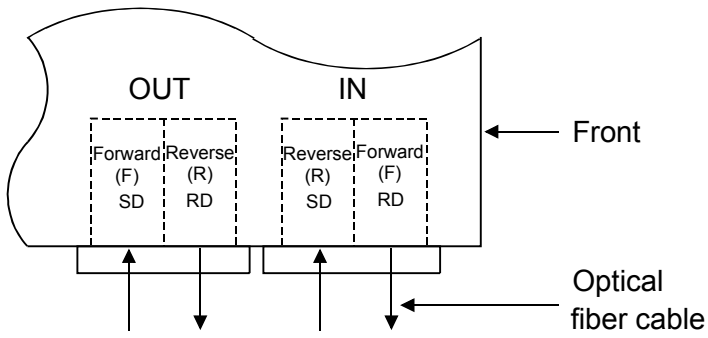
No.	Name	Contents																																																				
6) *1	<b>Conditions setting switch</b> <table border="1" style="display: inline-table; vertical-align: middle;"> <tr> <td>OFF</td> <td>ON</td> <td>OFF</td> <td>ON</td> <td>SW</td> </tr> <tr> <td>PC</td> <td>REMOTE</td> <td><input type="checkbox"/></td> <td><input type="checkbox"/></td> <td>1</td> </tr> <tr> <td>N.ST</td> <td>MNG</td> <td><input type="checkbox"/></td> <td><input type="checkbox"/></td> <td>2</td> </tr> <tr> <td>PRM</td> <td>D.PRM</td> <td><input type="checkbox"/></td> <td><input type="checkbox"/></td> <td>3</td> </tr> <tr> <td colspan="2">STATION SIZE (8.16.32.64)</td> <td><input type="checkbox"/></td> <td><input type="checkbox"/></td> <td>4</td> </tr> <tr> <td colspan="2"></td> <td><input type="checkbox"/></td> <td><input type="checkbox"/></td> <td>5</td> </tr> <tr> <td colspan="2">LB/LW SIZE (2.4.6.8K)</td> <td><input type="checkbox"/></td> <td><input type="checkbox"/></td> <td>6</td> </tr> <tr> <td colspan="2"></td> <td><input type="checkbox"/></td> <td><input type="checkbox"/></td> <td>7</td> </tr> <tr> <td colspan="2"></td> <td><input type="checkbox"/></td> <td><input type="checkbox"/></td> <td>8</td> </tr> </table>	OFF	ON	OFF	ON	SW	PC	REMOTE	<input type="checkbox"/>	<input type="checkbox"/>	1	N.ST	MNG	<input type="checkbox"/>	<input type="checkbox"/>	2	PRM	D.PRM	<input type="checkbox"/>	<input type="checkbox"/>	3	STATION SIZE (8.16.32.64)		<input type="checkbox"/>	<input type="checkbox"/>	4			<input type="checkbox"/>	<input type="checkbox"/>	5	LB/LW SIZE (2.4.6.8K)		<input type="checkbox"/>	<input type="checkbox"/>	6			<input type="checkbox"/>	<input type="checkbox"/>	7			<input type="checkbox"/>	<input type="checkbox"/>	8	Operation condition setting (factory setting at the time of shipping: all off)							
		OFF	ON	OFF	ON	SW																																																
		PC	REMOTE	<input type="checkbox"/>	<input type="checkbox"/>	1																																																
		N.ST	MNG	<input type="checkbox"/>	<input type="checkbox"/>	2																																																
		PRM	D.PRM	<input type="checkbox"/>	<input type="checkbox"/>	3																																																
		STATION SIZE (8.16.32.64)		<input type="checkbox"/>	<input type="checkbox"/>	4																																																
				<input type="checkbox"/>	<input type="checkbox"/>	5																																																
		LB/LW SIZE (2.4.6.8K)		<input type="checkbox"/>	<input type="checkbox"/>	6																																																
				<input type="checkbox"/>	<input type="checkbox"/>	7																																																
		<input type="checkbox"/>	<input type="checkbox"/>	8																																																		
		<table border="1"> <thead> <tr> <th>SW</th> <th>Contents</th> <th colspan="2">OFF</th> <th colspan="2">ON</th> </tr> </thead> <tbody> <tr> <td>1</td> <td>Network type</td> <td colspan="2">PLC to PLC network</td> <td colspan="2">Remote I/O network</td> </tr> <tr> <td>2</td> <td>Station type</td> <td colspan="2">Normal station</td> <td colspan="2">Control station</td> </tr> <tr> <td>3</td> <td>Use parameters</td> <td colspan="2">Parameters in common</td> <td colspan="2">Default Parameters</td> </tr> <tr> <td>4</td> <td rowspan="2">Number of stations [ Valid when SW3 is ON ]</td> <td>OFF</td> <td>8 stations</td> <td>ON</td> <td>16 stations</td> </tr> <tr> <td>5</td> <td>OFF</td> <td>8 stations</td> <td>ON</td> <td>16 stations</td> </tr> <tr> <td>6</td> <td rowspan="2">B/W number of general point [ Valid when SW3 is ON ]</td> <td>OFF</td> <td>2k points</td> <td>ON</td> <td>4k points</td> </tr> <tr> <td>7</td> <td>OFF</td> <td>2k points</td> <td>ON</td> <td>4k points</td> </tr> <tr> <td>8</td> <td colspan="4">Not used (always off)</td> <td></td> </tr> </tbody> </table>	SW	Contents	OFF		ON		1	Network type	PLC to PLC network		Remote I/O network		2	Station type	Normal station		Control station		3	Use parameters	Parameters in common		Default Parameters		4	Number of stations [ Valid when SW3 is ON ]	OFF	8 stations	ON	16 stations	5	OFF	8 stations	ON	16 stations	6	B/W number of general point [ Valid when SW3 is ON ]	OFF	2k points	ON	4k points	7	OFF	2k points	ON	4k points	8	Not used (always off)				
SW	Contents	OFF		ON																																																		
1	Network type	PLC to PLC network		Remote I/O network																																																		
2	Station type	Normal station		Control station																																																		
3	Use parameters	Parameters in common		Default Parameters																																																		
4	Number of stations [ Valid when SW3 is ON ]	OFF	8 stations	ON	16 stations																																																	
5		OFF	8 stations	ON	16 stations																																																	
6	B/W number of general point [ Valid when SW3 is ON ]	OFF	2k points	ON	4k points																																																	
7		OFF	2k points	ON	4k points																																																	
8	Not used (always off)																																																					
7)	Connector	Connect the optical fiber cable.  																																																				

\*1: When the setting has been changed with the CPU module powered ON, reset the CPU module (Shift the RUN/STOP key switch from RESET to any other than RESET.)

Note that resetting the CPU module is not needed for mode "D" to "F".

\*2: The settings are enabled when the module is a control station in the PLC to PLC network.

## 5. Wiring

### 5.1 Precautions for Laying Optical Fiber Cables

(1) When connecting an optical fiber cable, the following restrictions on the bending radius must be observed.

Make sure of the specifications of the cable to be used.

(2) The optical fiber cable is wired in the following manner.

There is no problem even if not wiring in order of the station number.

There is no problem even if station how many become control station.

(a) AJ71LP21GE-AJ71LP21GE

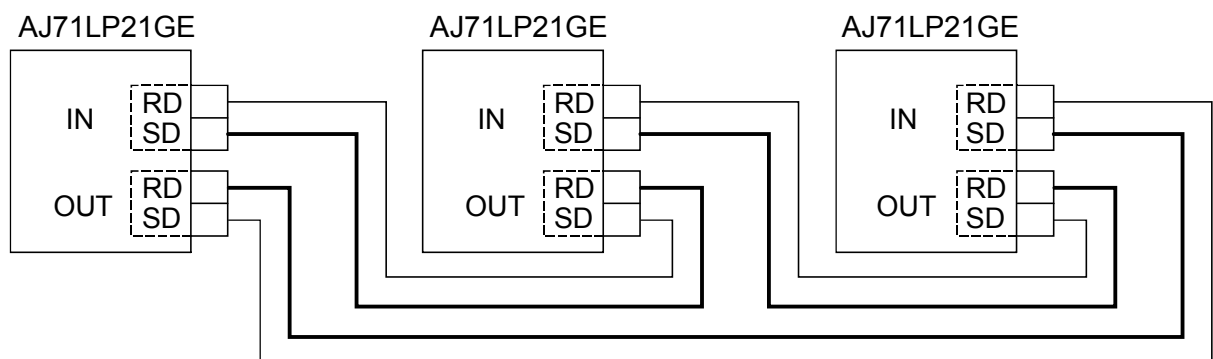

(b) AJ71LP21GE-AJ72LP25GE

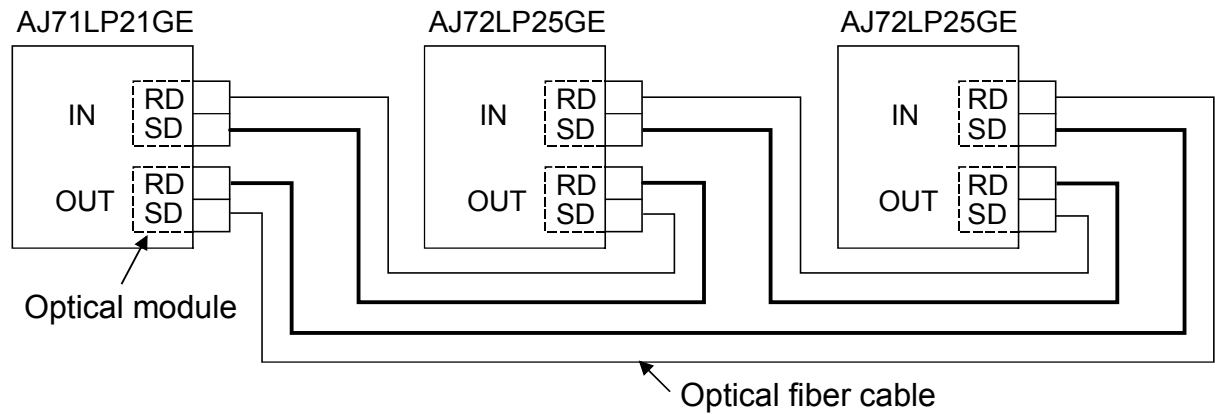

- (3) When laying the optical fiber cable, do not touch the fiber core of the cable connector or module connector, or let dirt or dust collect on it. If oil from the hands, dirt or dust should adhere to the core, the transmission loss will increase, causing a malfunction in the data link. Also, do not remove the cover from the module connector until an optical fiber cable is connected.
- (4) When attaching or detaching the optical fiber cable to/from the module, hold the cable connector securely with the hands.
- (5) Connect the cable connector and module connector securely until you hear a "click" sound.
- (6) Please wire IN/OUT of the connector for the cable correctly. Please do loopback test, the set confirmation test, and the bureau order confirmation test after wiring. It might be generated that a baton abnormal passing cannot be generated when miswiring and the downed bureau which cannot do the loopback of an arbitrary bureau do the row again even by the reclosing of the power supply.
- (7) Completely turn off the externally supplied power used in the system when connecting or disconnecting the cable.

## 6. External Dimensions

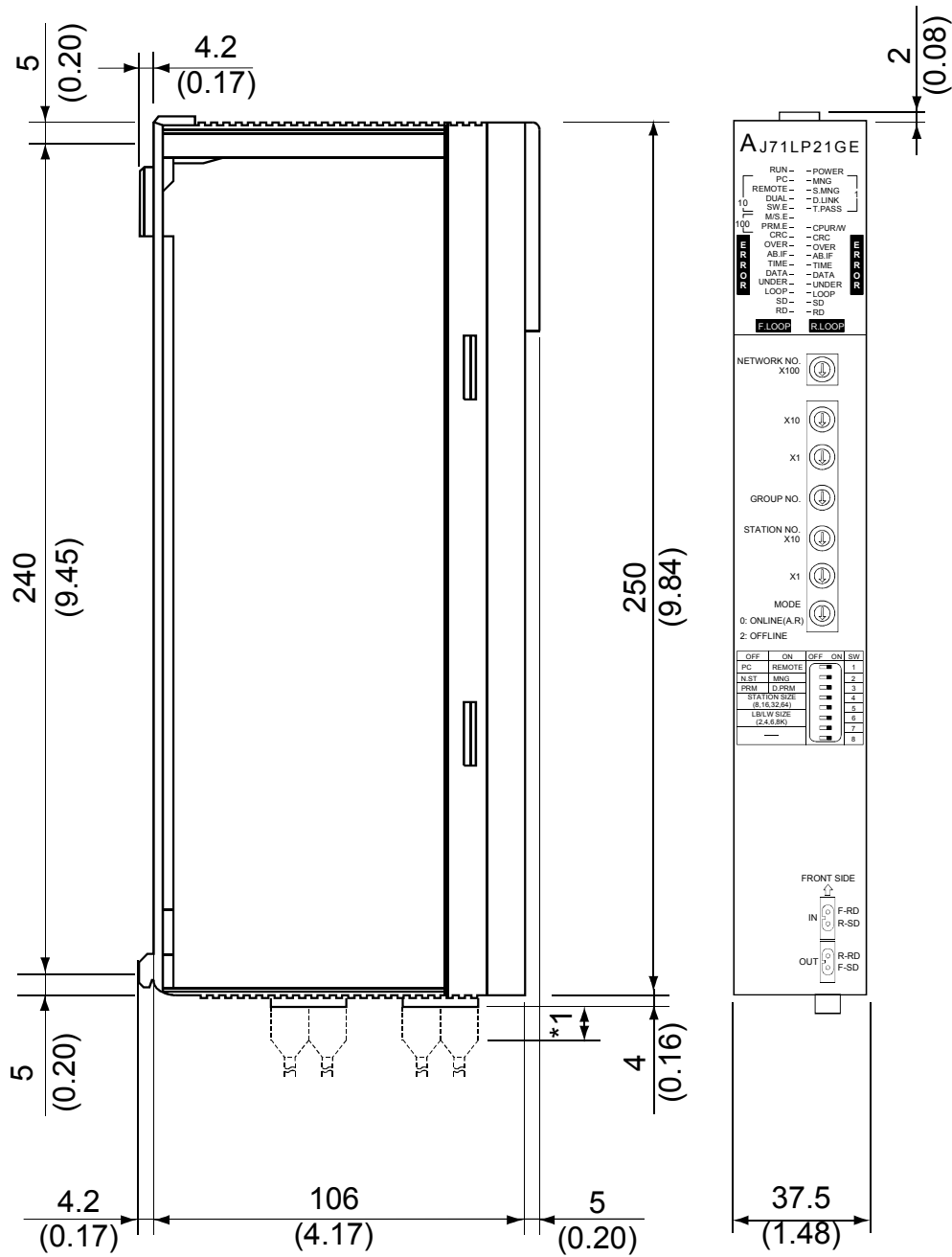

Unit: mm (in.)

\*1: Please confirm details to Mitsubishi Electric System Service Corporation.

## WARRANTY

Mitsubishi will not be held liable for damage caused by factors found not to be the cause of Mitsubishi; machine damage or lost profits caused by faults in the Mitsubishi products; damage, secondary damage, accident compensation caused by special factors unpredictable by Mitsubishi; damages to products other than Mitsubishi products; and to other duties.

Country/Region	Sales office/Tel	Country/Region	Sales office/Tel
U.S.A	Mitsubishi Electric Automation Inc. 500 Corporate Woods Parkway Vernon Hills, IL 60061, U.S.A. Tel : +1-847-478-2100	China	Mitsubishi Electric Automation (China) Ltd. 4/F Zhi Fu Plazz, No.80 Xin Chang Road, Shanghai 200003, China Tel : +86-21-6120-0808
Brazil	MELCO-TEC Rep. Com.e Assessoria Tecnica Ltda. Rua Correia Dias, 184, Edificio Paraiso Trade Center-8 andar Paraiso, Sao Paulo, SP Brazil Tel : +55-11-5908-8331	Taiwan	Setsuyo Enterprise Co., Ltd. 6F No.105 Wu-Kung 3rd.Rd, Wu-Ku Hsiang, Taipei Hsine, Taiwan Tel : +886-2-2299-2499
Germany	Mitsubishi Electric Europe B.V. German Branch Gothaer Strasse 8 D-40880 Ratingen, GERMANY Tel : +49-2102-486-0	Korea	Mitsubishi Electric Automation Korea Co., Ltd. 1480-6, Gayang-dong, Gangseo-ku Seoul 157-200, Korea Tel : +82-2-3660-9552
U.K	Mitsubishi Electric Europe B.V. UK Branch Travellers Lane, Hatfield, Hertfordshire., AL10 8XB, U.K. Tel : +44-1707-276100	Singapore	Mitsubishi Electric Asia Pte, Ltd. 307 Alexandra Road #05-01/02, Mitsubishi Electric Building, Singapore 159943 Tel : +65-6470-2480
Italy	Mitsubishi Electric Europe B.V. Italian Branch Centro Dir. Colleoni, Pal. Perseo-Ingr.2 Via Paracelso 12, I-20041 Agrate Brianza., Milano, Italy Tel : +39-039-60531	Thailand	Mitsubishi Electric Automation (Thailand) Co., Ltd. Bang-Chan Industrial Estate No.111 Moo 4, Serithai Rd, T.Kannayao, A.Kannayao, Bangkok 10230 Thailand Tel : +66-2-517-1326
Spain	Mitsubishi Electric Europe B.V. Spanish Branch Carretera de Rubi 76-80, E-08190 Sant Cugat del Valles, Barcelona, Spain Tel : +34-93-565-3131	Indonesia	P.T. Autoteknindo Sumber Makmur Muara Karang Selatan, Block A/Utara No.1 Kav. No.11 Kawasan Industri Pergudangan Jakarta - Utara 14440, P.O.Box 5045 Jakarta, 11050 Indonesia Tel : +62-21-6630833
France	Mitsubishi Electric Europe B.V. French Branch 25, Boulevard des Bouvets, F-92741 Nanterre Cedex, France Tel : +33-1-5568-5568	India	Messung Systems Pvt, Ltd. Electronic Sadan NO:III Unit No15, M.I.D.C Bhosari, Pune-411026, India Tel : +91-20-2712-3130
South Africa	Circuit Breaker Industries Ltd. Private Bag 2016, ZA-1600 Isando, South Africa Tel : +27-11-928-2000	Australia	Mitsubishi Electric Australia Pty. Ltd. 348 Victoria Road, Rydalmere, N.S.W 2116, Australia Tel : +61-2-9684-7777

## MITSUBISHI ELECTRIC CORPORATION

HEAD OFFICE : TOKYO BUILDING, 2-7-3 MARUNOUCHI, CHIYODA-KU, TOKYO 100-8310, JAPAN  
NAGOYA WORKS : 1-14, YADA-MINAMI 5-CHOME, HIGASHI-KU, NAGOYA, JAPAN

When exported from Japan, this manual does not require application to the Ministry of Economy, Trade and Industry for service transaction permission.

Specifications subject to change without notice.